

## MEDIAJET – LINX 5900 (4900) / CJ400 inkjet printer head installation

### Installation Instructions V02

#### Document Change History

Vers.	Status:	Date:	Change:
V00	Released	28.02.2013	Document issued
V01	Released	11.02.2015	Addition of new printer type (LINX 5900)
V02	Released	02.06.2015	Picture exchange, compatibility

#### Table of Contents

1	Introduction-----	1
2	Required Accessories and Documentation -----	1
3	Mount the printer head onto MEDIAJET-----	2
4	Imprint-----	4

### 1 Introduction

This document describes installation and connection of the LINX 5900 (4900) / CJ400 (LINX) inkjet printer head to the MEDIAJET (MJ) dish filler. Before starting with the installation, please carefully read MJ and LINX operating instructions. Please note that MJ units manufactured before March 2013 (serial numbers below 10313569/11313248) are not compatible with LINX inkjet printers.

### 2 Required Accessories and Documentation

The components listed below are required to connect the inkjet printer to MEDIAJET.

Components available from INTEGRA Biosciences:

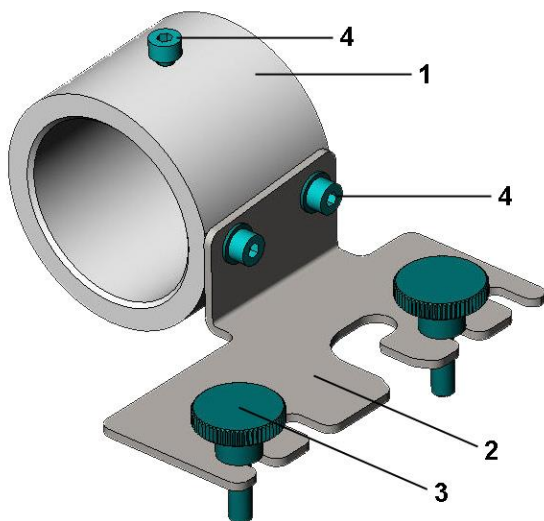

- MEDIAJET Dish Filler (Part no. 103005 / 103006 / 113000 / 113001 / 113002)
- MJ Operating Instructions (Part no. 103950)
- Connection kit for LINX 5900 (4900) / CJ400 (Part no. 113845)

Consisting of:

- 1 Printer head retainer
- 2 Mounting bracket
- 3 Knurled head screws M5x16 (2x)
- 4 Allen screw M4x8

Interface cable MJ to LINX (113853; not shown)

Installation Instructions Connection Kit for LINX 5900 (4900) / CJ400 (103981, this document)

### 3 Mount the printer head onto MEDIAJET

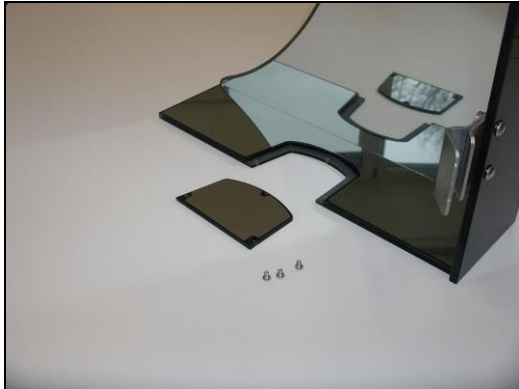

Remove the slot cover on the back side of the MEDIAJET Plexiglas safety cover.



Spear and remove the two screw caps (Part no. 103628) which cover the threads of the print head fixing points using a thin screwdriver.

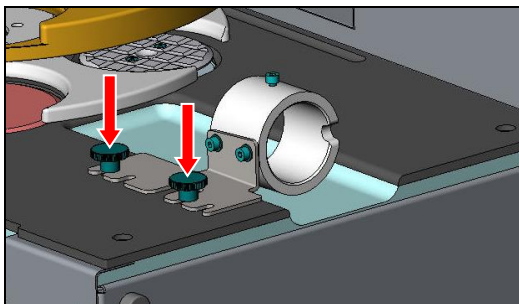

Fix the printer head onto the MEDIAJET using the two knurled head screws (3).

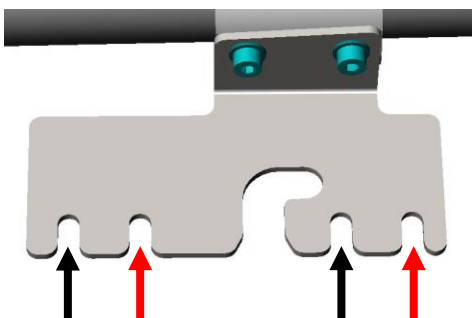

Use the anterior slots (black arrows) when printing on 90 mm Petri dishes or use the posterior slots (red arrows) when printing on 60 mm Petri dishes to fix the Mounting bracket (2) onto the MEDIAJET.

# INTEGRA

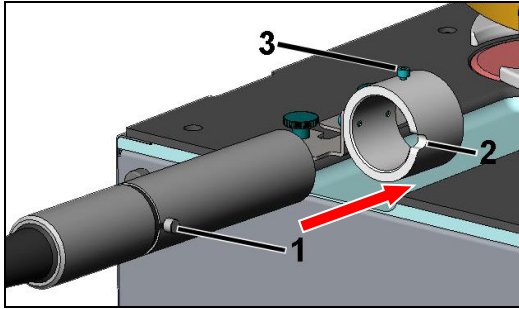

**LINX 5900 (4900):** Insert the printer head into the metal ring (Printer head retainer) of the adapter and align the pin (1) of the printer head with the notch (2) of the adapter. Fix the printer head with the Allen screw M4x8 (3).

OR

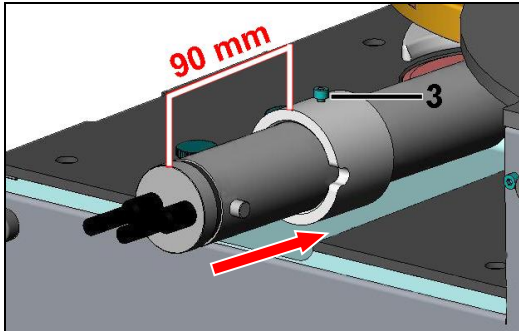

**LINX CJ400:** Insert the printer head into the metal ring (Printer head retainer) of the adapter such that the distance between the rear part of the printer head and the metal ring is 90 mm. Fix the printer head with the Allen screw M4x8 (3).

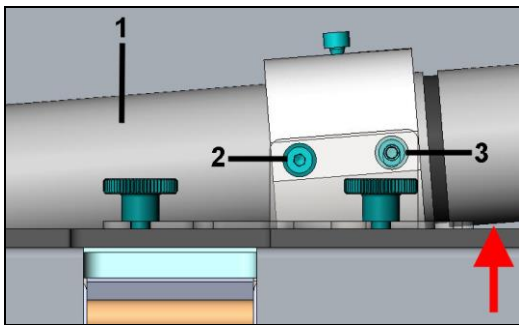

**LINX 5900 (4900):** Tighten the anterior Allen screw M4x8 (2). Push the printer head (1) to the upper stop of the posterior screw hole and tighten the Allen screw M4x8 (3).

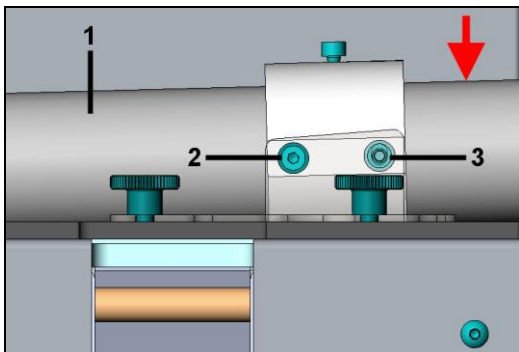

**LINX CJ400:** Tighten the anterior Allen screw M4x8 (2). Push the printer head (1) to the lower stop of the posterior screw hole and tighten the Allen screw M4x8 (3).



Insert the Mini-DIN 8 poles plug of the Interface cable (Part no. 113853) into the socket labeled with INKJET on the rear panel of the MEDIAJET.

Insert the plug at the other end of the interface cable according to the LINX Operating Instructions.

## 4 Imprint

© 2015 INTEGRA Biosciences AG

All rights relating to this documentation reserved. INTEGRA Biosciences AG especially reserves the rights of duplication, processing, translation and display format. Any reproduction of parts or the entire documentation, or storage thereof on electronic media, or processing or dissemination thereof, requires the prior written consent of INTEGRA Biosciences AG.

This Installation Instructions has the part number 103981; the version is V02.

### **Manufacturer**

INTEGRA Biosciences AG  
CH-7205 Zizers, Switzerland  
T +41 81 286 95 30  
F +41 81 286 95 33

[info@integra-biosciences.com](mailto:info@integra-biosciences.com)  
<http://www.integra-biosciences.com>