

# INTEGRA



## **MINI 96** Operating instructions



## Declaration of conformity

**INTEGRA Biosciences AG – 7205 Zizers, Switzerland**

declares on its own responsibility that the devices

Description	Models
<b>MINI 96</b>	<b>4801, 4802, 4803, 4804</b>

comply with:

<b>EU Directives</b>	<b>Scope</b>	<b>Date effective</b>
2014/35/EU	Low voltage directive (LVD)	20.04.2016
2014/30/EU	Electromagnetic compatibility (EMC)	20.04.2016
2012/19/EC	Waste electrical and electronic equipment (WEEE)	14.02.2014
2011/65/EC	Restriction of hazardous substances (RoHS)	03.01.2013

<b>EU Regulations</b>	<b>Scope</b>	<b>Date effective</b>
1907/2006	Registration, evaluation, authorisation and restriction of chemicals (REACH)	01.06.2007

<b>EU Standards</b>	<b>Scope</b>
EN 9001:2015	Quality Management
EN 61010-1:2010	Safety general laboratory equipment
EN 61326-1:2013	Electromagnetic compatibility laboratory equipment
EN 61010-2-081:2015	Safety automatic laboratory equipment

<b>GBR Regulations</b>	<b>Scope</b>	<b>Date effective</b>
S.I. 2016/1101	Electrical equipment safety	08.12.2016
S.I. 2016/1091	Electromagnetic compatibility (EMC)	08.12.2016
S.I. 2013/3113	Waste electrical and electronic equipment (WEEE)	01.01.2019
S.I. 2012/3032	Restriction of hazardous substances (RoHS)	02.01.2013

<b>GBR Standards</b>	<b>Scope</b>
BS 61010-1:2010	Safety general laboratory equipment
BS 61010-2-081:2015	Safety automatic laboratory equipment
BS 63000:2018	Restriction of hazardous substances (RoHS)

## MINI 96 – Declaration of conformity

---

<b>USA Regulations</b>	<b>Scope</b>
------------------------	--------------

47 CFR Part 15 (FCC)	Electromagnetic compatibility (EMC)
----------------------	-------------------------------------

17 CFR Parts 240 & 249b	Dodd frank “Conflict minerals”
-------------------------	--------------------------------

27 CCR Parts 25102-27001	Proposition 65: The safe drinking water and toxic enforcement act
--------------------------	---

<b>USA Standards</b>	<b>Scope</b>
----------------------	--------------

UL 61010-1:2012	Safety general laboratory equipment
-----------------	-------------------------------------

UL 61010-2-081:2015	Safety automatic laboratory equipment
---------------------	---------------------------------------

<b>CAN Standards</b>	<b>Scope</b>
----------------------	--------------

CSA-C22.2 No. 61010-1	Safety general laboratory equipment
-----------------------	-------------------------------------

CSA C22.2 No. 61010-2-081	Safety automatic laboratory equipment
---------------------------	---------------------------------------

<b>CHN Regulations</b>	<b>Scope</b>	<b>Date effective</b>
------------------------	--------------	-----------------------

Order 32/2016	Restriction of hazardous substances (RoHS)	01.07.2016
---------------	--	------------

<b>CHN Standards</b>	<b>Scope</b>
----------------------	--------------

SJ/T 11364-2014	Restriction of hazardous substances (RoHS)
-----------------	--

<b>JPN Regulations</b>	<b>Scope</b>	<b>Date effective</b>
------------------------	--------------	-----------------------

PSE (Denan) Law	Electrical appliance and material safety law	01.01.2014
-----------------	--	------------

Zizers, February 19, 2021

  
Urs Hartmann  
CEO

  
Thomas Neher  
Quality Manager

## Table of Contents

<b>Chapter 1</b>	<b>Introduction</b>	
1.1	Symbols used .....	7
1.2	Intended use .....	7
1.3	Safety notes .....	8
<b>Chapter 2</b>	<b>Description of the device</b>	
2.1	Scope of delivery .....	9
2.2	Overview of MINI 96 .....	9
2.2.1	MINI 96 device .....	9
2.2.2	MINI 96 control unit .....	10
2.2.3	Display .....	10
2.2.4	Touch wheel .....	11
2.2.5	Left and right arrow buttons .....	11
2.2.6	PURGE button .....	11
2.2.7	RUN button .....	11
<b>Chapter 3</b>	<b>Installation</b>	
3.1	Operating environment .....	12
3.2	Setting up and moving of the device .....	12
3.3	Installation of stages .....	13
3.3.1	Base stage .....	13
3.3.2	Second stage .....	13
3.3.3	Two position stage .....	13
3.4	Settings - adapt your MINI 96 .....	14
3.4.1	Position settings .....	14
3.4.2	Preferences .....	15
3.4.3	Calibration & Services .....	17
3.4.4	Communications .....	18
3.4.5	Device Information .....	18
3.4.6	Park Head .....	18
3.4.7	Language .....	18
3.4.8	Write protect .....	19

## Chapter 4 Operation

4.1	Turn on/off the device.....	20
4.2	Attaching and removing GripTips .....	20
4.2.1	Loading tips from a rack with 96 tips.....	20
4.2.2	Loading tips from a rack with 384 tips.....	20
4.2.3	Partially tips loading.....	21
4.2.4	Ejecting used GripTips.....	22
4.3	Start pipetting .....	22
4.3.1	Pipetting.....	22
4.3.2	Setting pipetting height .....	22
4.3.3	Blowout/blowin modes .....	23
4.3.4	Recommendations for pipetting .....	24
4.3.5	Pipetting between 96-384 well plates .....	25
4.3.6	Pipetting with the Two position stage.....	25
4.4	Pipetting options and settings .....	26
4.4.1	Edit option .....	26
4.4.2	Volume selection.....	26
4.4.3	Speed selection .....	27
4.4.4	Pace.....	28
4.4.5	Count, Mix Cycle and Rows.....	28
4.4.6	Custom.....	28
4.5	Troubleshooting/FAQ .....	29

## Chapter 5 Programs

5.1	Overview programs .....	30
5.2	Detailed description of programs.....	31
5.2.1	Pipet .....	31
5.2.2	Repeat Dispense .....	32
5.2.3	Pipet/Mix .....	34
5.2.4	Sample Dilute .....	35
5.2.5	Manual Pipet .....	36
5.2.6	Reverse Pipet .....	37
5.2.7	Variable Dispense .....	38
5.2.8	Multi Aspirate .....	39
5.2.9	Sample Dilute/Mix .....	40
5.2.10	Serial Dilution .....	41
5.3	Custom step-based program.....	42
5.3.1	Program steps.....	42
5.3.2	Modify existing programs.....	44

**Chapter 6 Maintenance**

6.1	Cleaning .....	45
6.2	Decontamination .....	45
6.2.1	Two position stage .....	45
6.3	Leak test .....	46
6.4	Servicing .....	47
6.4.1	Changing O-rings of tip fittings .....	47
6.5	Calibration .....	48
6.6	Equipment disposal .....	48

**Chapter 7 Technical Data**

7.1	Environmental conditions .....	49
7.2	Specification of the device .....	49
7.3	Intellectual Property .....	50
7.4	Pipetting specifications .....	50
7.5	Pipetting Speeds .....	51

**Chapter 8 Accessories and consumables**

8.1	Accessories .....	52
8.2	Consumables .....	53
	<b>Imprint .....</b>	<b>57</b>

# 1 Introduction

These operating instructions contain all the information required for installation, operation and maintenance of MINI 96. This chapter informs about the symbols used in these operating instructions, the intended use of MINI 96 and the general safety instructions.

## 1.1 Symbols used

The operating instructions specifically advise of residual risks with the following symbols:

**WARNING**

*This safety symbol warns against hazards that could result in injury. It also indicates hazards for machinery, materials and the environment. It is essential that you follow the corresponding precautions.*

**CAUTION**

*This symbol cautions against potential material damage or the loss of data in a microprocessor controller. Follow the instructions.*

**NOTE**

*This symbol identifies important notes regarding the correct operation of the device and labor-saving features.*

The device is marked with the following symbols:

**BIOHAZARD**

*The device can be potentially biohazardous due to the use of biozardous substances by the operator.*

**CRUSHING OF HANDS**

*The hands may be squeezed, pulled in or otherwise injured by moving parts of the device.*

**UNPLUG**

*The power cable must be unplugged before the housing of the device is opened by a service technician.*

## 1.2 Intended use

MINI 96 is an electronic 96 channel hand held pipette designed for aspirating and dispensing aqueous solutions in the volume range of 0.5 µl to 1250 µl using GripTip pipette tips. MINI 96 is used like a hand held pipette. The movement and positioning of the pipette is supported by a servo assisted steering mechanism which allows fast, precise and stress free multichannel pipetting.

Any use of this device in a medical or IVD setting is the responsibility of the user.

If MINI 96 is used in a manner not specified by INTEGRA Biosciences, the protection provided by the MINI 96 may be impaired.

### 1.3 Safety notes

MINI 96 complies to the recognized safety regulations and is safe to operate. MINI 96 can only be operated when in perfect condition and while observing these operating instructions.

The device may be associated with residual risks if it is used or operated improperly by untrained personnel. Any person operating the MINI 96 must have read and understood these operating instructions, and particularly, the safety notes, or must have been instructed by supervisors so that safe operation of the device is guaranteed.

**WARNING**

*Do not use the MINI 96 near flammable material or in explosive areas. Also, do not pipette highly flammable liquids such as acetone or ether.*

*When handling dangerous substances, comply with the material safety data sheet (MSDS) and with all safety guidelines such as the use of protective clothing and safety goggles.*

**CAUTION**

*Do not immerse the pipette in liquid. The fluid can damage internal parts. Avoid pipetting of liquids whose vapors could attack the materials PA (polyamide), POM (polyoxymethylene), FPM (fluor-rubber), NBR (nitrile-rubber), CR (chloroprene), silicone. Corrosive vapors could also damage parts inside the device.*

*Do not open or modify MINI 96 in any way. The cover must not be removed. Repairs may only be performed by INTEGRA Biosciences or by an authorized after-sales service member.*

*Parts may be replaced with original INTEGRA Biosciences parts only.*

**NOTE**

*Prolonged exposure of the MINI 96 to UV-light can cause discoloration and/or yellowing of the control unit. However, this will not affect the performance of the device in any way.*

Regardless of the listed safety notes, additional applicable regulations and guidelines of trade associations, health authorities, trade supervisory offices, etc. must be observed.

Please visit our website [www.integra-biosciences.com](http://www.integra-biosciences.com) on a regular basis for up to date information regarding REACH classified chemicals contained in our products.



## 2 Description of the device

### 2.1 Scope of delivery

- MINI 96 pipette
- Base stage
- Second stage
- Power cable
- Mains adapter
- Replacement O-rings and removal tool (for 300 µl and 1250 µl pipettes)
- Replacement Magnetic covers
- Quick start guide



#### CAUTION

Verify the scope of delivery when unpacking the device and check for potential transportation damage. Do not operate a device that is damaged, instead contact your local INTEGRA representative.

### 2.2 Overview of MINI 96

#### 2.2.1 MINI 96 device

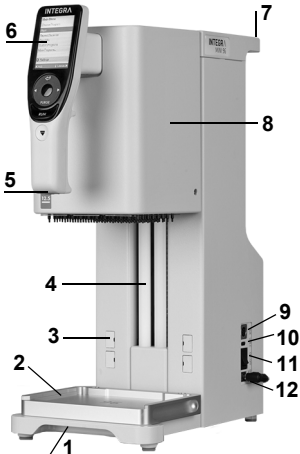

- 1 Carrying grip
- 2 Base stage on Deck
- 3 Magnetic covers, for Second stage
- 4 LED bars
- 5 Deck light
- 6 Control unit, see [2.2.2](#)
- 7 Carrying handle
- 8 Pipetting unit, to move up and down
- 9 AUX port
- 10 USB-C port
- 11 Main switch (ON | OFF)
- 12 DC Input for mains adapter

### 2.2.2 MINI 96 control unit



- 13 **Display**
- 14 **Back button**, to navigate backward
- 15 **Touch wheel**, spin to scroll and move the cursor
- 16 **OK button**, to make a selection
- 17 **Left and right arrow buttons**, for selections
- 18 **PURGE button**, to empty tips
- 19 **RUN button**, to start operations
- 20 **Tip ejector**

### 2.2.3 Display

The Display shows all pipetting programs.

The diagram illustrates the display content and control unit buttons for program selection and editing:

- Main Menu** (shown in the upper half of the display):
  - Choose Program
  - Pipet** (highlighted)
  - Repeat Dispense
  - Pipet/Mix
  - Custom Programs
  - More Programs...
  - Settings
- Options** are listed in the lower half:
  - Asp. Speed: 8
  - Disp. Speed: 8
  - Pipetting Height (with arrow icon)
- Run steps** are listed in the upper half:
  - current program: Pipet
  - instruction: Press RUN to start step 1
  - active step (orange): 1 Aspirate 50.0 µl
  - 2 Dispense 50.0 µl
- Control Unit Buttons:**
  - OK**: Pressed to confirm selection.
  - Edit**: Pressed to edit parameters.
  - Select and OK**: Pressed to confirm parameter changes.
  - ▶**: Arrow icon used to set pipetting height.

### 2.2.4 Touch wheel

The **Touch wheel** is fully operational with only one hand. Rotational finger movements translate into up and down cursor movement on the display. The **Touch wheel** is fully functional with the use of latex gloves.

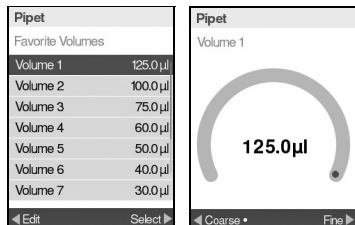

Move finger on the **Touch wheel** to choose (and highlight) an option on the display. Press **OK** (16) to make the selection.

When a setting dial is displayed, spin the **Touch wheel** to change the value and press **OK**.

### 2.2.5 Left and right arrow buttons

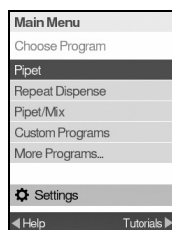

At times, you will see ◀ and ▶ on a display screen. These buttons are used to select options.

Press ◀ to select the option indicated with the left arrow (Help, in the example beside). Press ▶ to select the option indicated with the right arrow (Tutorials, in the example).

### 2.2.6 PURGE button

During pipetting, you can interrupt the current pipetting protocol and purge all remaining liquid currently in the GripTips. To do so, press **PURGE** (18).

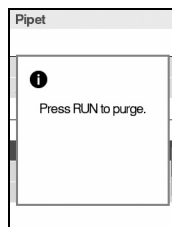

The pipette will display a prompt.

To proceed, press and release **RUN**. Upon completion of the purging, the first step in the current program will be displayed.

### 2.2.7 RUN button

Press and release **RUN** (19) to initiate aspiration, dispense, mix, purge, and special pipetting operations.

During dispense, you can press and hold **RUN** to perform a two-step blowout, see [“4.3.3 Blowout/blowin modes”](#) on page 23.

### 3 Installation

#### 3.1 Operating environment

MINI 96 has been designed for use in a laboratory. It shall be operated in a dry and dust-free location with a temperature of 5–40 °C and a maximal (non-condensing) relative humidity of 80 %.

#### 3.2 Setting up and moving of the device

The MINI 96 must be set up on a cleaned, dry and horizontal surface.

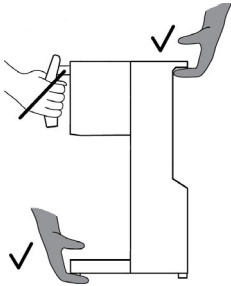

Hold the **Carrying grip** (1) and **Carrying handle** (7) to lift the MINI 96.



**WARNING**

*The device must not be carried on the control unit because it will be damaged.*

Leave at least 5 cm of free space on the back for air circulation and to allow easy connection of the mains cable.

### 3.3 Installation of stages

#### 3.3.1 Base stage

Put the **Base stage** (2) on the two **Deck pins**. It can be placed on either side. The graphic “96” or “384” must match the tip rack or well plate pattern.

#### 3.3.2 Second stage

The **Second stage** can be used as a second position. Source liquids can be placed on the **Base stage**, and the target, i.e. the well plate, can be slid on the **Second stage** for filling.

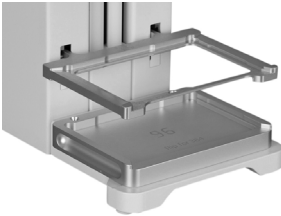

To install the **Second stage**, remove the two **Magnetic covers** (3) by pressing on one side or using a GripTip. Insert the **Second stage** with the desired side (96 or 384 format) facing upwards.

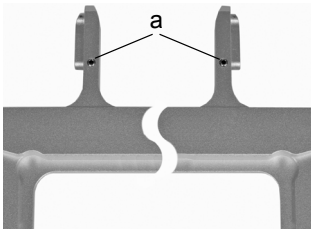

If it is noticed that the **Second stage** is not level, use a 1.27 hexagon screwdriver and tighten or loosen the two screws (a) on the stage the same amount, to ensure that both sides are the same height.

When the 96 side needs to be adjusted, screw on the 384 side and vice versa.

Tightening clockwise will move the stage very slightly down.

#### 3.3.3 Two position stage

The optional Two position stage (see "Accessories" on page 52) is required for partial tip loading, filling partial plates or performing sample transfers and dilutions within a plate.

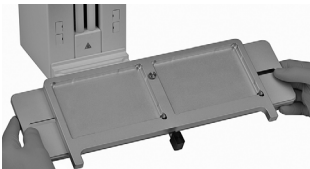

Switch off the device.

Put the Two position stage on the two **Deck pins**.

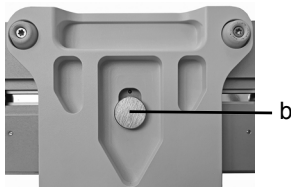

Hold the device by the **Carrying handle** (7) and tilt it slightly backwards. Fix the stage from the underside of the deck with the large screw (b).

### 3.4 Settings - adapt your MINI 96

The Settings provides options to adapt the device to appropriate applications, setting personal preferences, calibration, computer connectivity and storing owner information.

Settings mode	Description
Position Settings	Enables the ability to override the active pipette height.
Preferences	Customizes the system parameters.
Calibration / Service	Sets calibration and service history options.
Communications	Enables communication between your MINI 96 and a PC.
Device Information	View your pipette's serial number, software version and set a personal ID.
Park Head	Fixes the pipetting unit for safe shipping.
Language	Sets display language.
Write Protect	Protects programs or menu options from modification.
Time / Date	Sets time and date.

The Help information describes the programs and some settings, press ◀ to select the Help option.

#### 3.4.1 Position settings

Press **OK** to access. The desired setting is saved directly.

Position	Description	Range
Pipetting Height Override	Enables the pipetting height override. The active pipetting height can be overcome by pushing down on the control unit for a short time. Press <b>OK</b> to toggle between On and Off.	✓/✖ (On/Off)

### 3.4.2 Preferences

Preferences customizes your system parameters. Use the **Touch wheel** to select an option and press **OK** to access. The desired settings are saved directly.

Preferences	Description	Range
Deck Brightness	Sets brightness of the deck light from off, 1 (weak) to 10 (bright).	Off 1-10
Dim Time	Sets the time to enter the dim mode.	2-30 min
LED Bar Brightness	Sets brightness of the LED bars on the device from off, 1 (weak) to 10 (bright).	Off 1-10
Display Brightness	Sets brightness of the display from 1 (weak) to 10 (bright).	1-10
Handle Sensitivity	Sets the movement sensitivity of the pipetting unit from 1 (low) to 10 (high).	1-10
Sound	Select an option and press <b>OK</b> to activate or deactivate beep tones: <ul style="list-style-type: none"> <li>• <b>Step Complete</b>: at the end of a program step</li> <li>• <b>Program Complete</b>: at program completion</li> <li>• <b>PURGE Key</b>: when PURGE is pressed.</li> <li>• <b>Messages</b>: when a message appears.</li> <li>• <b>Error Messages</b>: when an error message appears or when illegal data entry is attempted.</li> <li>• <b>Touch Wheel</b>: When spinning the Touch wheel.</li> <li>• <b>Last dispense</b>: before the last dispense in Repeat Dispense and Variable Dispense.</li> </ul>	✓/* (On/Off)
Main Menu	Define which programs are displayed in the Main Menu. Select the most often used programs and press <b>OK</b> to change their status to either On or Off. Programs marked On are displayed in the Main Menu, and all others under More Programs.	✓/* (On/Off)
Touch Wheel	Adjust your Touch wheel spin sensitivity.	Low, Medium, High

Pipetting	<p>Select an option and press <b>OK</b>.</p> <ul style="list-style-type: none"> <li>• <b>PURGE Speed:</b> Choose the desired purge speed.</li> <li>• <b>BlowIn Delay:</b> Choose a timed delay between the blowout and the blowin at the end of a dispense, if no two step blowout is performed, see 4.3.3.</li> <li>• <b>Extend Volume:</b> For pipetting below the volume range specified:  50 µl pipette: (1.0)–2–50 µl  125 µl pipette: (2.0)–5–125 µl  300 µl pipette: (5.0)–10–300–(310) µl  1250 µl pipette: (25)–50–1250 µl  The volumes in brackets refer to extended volumes, e.g. extend the minimal pipetting volume of a 125 µl pipette from 5 µl to 2 µl.</li> <li>• <b>Speed Table:</b> Change the default pipetting speed (see 7.5) of any speed step. Press ► to save.</li> <li>• <b>Pace in Custom:</b> Allows for continuous dispensing by pressing and holding <b>RUN</b> during consecutive dispenses. To activate this feature, set the time gap between dispenses.</li> </ul>	1-10  None/ 0.5-5.0 s  ✓/✗ (On/Off)      µl/s   None/1-10 (slow-fast)
-----------	--	---

**NOTE**

*Extending the volume range is not recommended. Full functionality and specified accuracy/precision cannot be guaranteed.*



### 3.4.3 Calibration & Services

These options enable you to set calibration features and review service history.

Calibration & Services	Description	Range
Calibration	<p>Allows for re-calibration of MINI 96 to restore accuracy. The calibration factors for Pipet and Repeat type are displayed. To edit the calibration volumes, press ◀.</p> <ul style="list-style-type: none"> <li>• <b>Target Volume:</b> This is the volume you are interested in using for the calibration.</li> <li>• <b>Actual Volume:</b> This is the measured volume obtained when dispensing the target volume.</li> <li>• <b>Current Factor:</b> Displays the factor currently in use. This factor should be the same as specified on the latest calibration certificate.</li> </ul> <p>Enter the Actual Volume and press <b>OK</b>. Press <b>Start ▶</b> to calculate and save the new Current Factor. Press ◀ <b>Reset</b> to set the correction factor back to the original Factory Factor 1.0000.</p>	-
Calibration Reminder	<p>Sets a calibration reminder based on a number of pipetting cycles. When the calibration reminder is displayed, press any key to confirm. However, the reminder will reappear every time the pipette is turned on until you change the reminder time or use the reset option.</p> <ul style="list-style-type: none"> <li>• <b>Reminder Time:</b> Press <b>OK</b> to turn the reminder timer On or Off. Select Days to define the reminder time.</li> <li>• <b>Reminder Cycles:</b> Use the <b>Touch wheel</b> to set a reminder interval for calibration (time in thousands of cycles).</li> </ul> <p><b>Remind in:</b> Displays the residual amount of day/cycles before calibration is required.</p> <p>◀ <b>Reset:</b> Resets the timer back to the original factory interval. Press ▶ to save the defined interval.</p>	✓/* (On/Off) 1 - 365 days 1 - 240 K
Service History	<p>Displays notes of any service that took place on the MINI 96 listed newest entry first.</p>	-

### 3.4.4 Communications

The latest firmware for MINI 96 can be loaded from a PC via a USB-C to USB communication cable.

Communi-cations	Description
USB	Connect the USB-C cable between MINI 96 and a PC. Press <b>OK</b> to begin bi-directional communication. To exit the communications mode turn off MINI 96.

### 3.4.5 Device Information

Device Information	Description
MINI 96	Information about your MINI 96, such as volume range, owner, serial number, head number, firmware (FW) version and other device details are displayed. <b>Edit Owner:</b> Press ◀ to enter the user name for your pipette. Use the <b>Touch wheel</b> to highlight a character and press <b>OK</b> . You can press ◀ to Delete the last character entered. After entering the desired text, press ▶ to save.

### 3.4.6 Park Head

Park Head	Description
Park Head	Fixes the pipetting unit for safe shipping, for example back to INTEGRA for calibration. Make sure GripTips are ejected and the deck is cleared. Press <b>RUN</b> to start the park routine. The pipette moves to park position and can then be turned off.

### 3.4.7 Language

Language	Description
Language	You can choose the language in which all screens are displayed. Scroll to the desired language, press <b>OK</b> and ▶ to save.

### 3.4.8 Write protect

Select this option to protect programs and menu options from inadvertent modification. The pipetting programs can still be used.

Write protect	Description	Range
	Select an option and press <b>OK</b> to switch protection on or off: <ul style="list-style-type: none"> <li>• <b>Standard Programs</b></li> <li>• <b>Custom Programs</b></li> <li>• <b>Calibration</b></li> <li>• <b>Settings</b></li> <li>• <b>Password Protection:</b> Protect the access to the write protect menu by selecting “✓”.</li> <li>• <b>Edit Password:</b> if password protect is switched on. To enter a password use the <b>Touch wheel</b> to highlight a character and press OK. Press ► to save the password. The password must be entered before you can access the write protect menu.</li> </ul>	✓/✖ (On/Off)

Keep the password in a safe place. Should you lose your password, contact INTEGRA Biosciences for assistance in retrieving it.

## 4 Operation

### 4.1 Turn on/off the device

Turn on:



**CAUTION**

Remove hands from **Control unit** (6) at switch on and during homing.

Press the **Main switch** (11) to turn on. You are prompted to press **RUN** to perform a vertical homing routine. After homing the Main Menu is displayed.

Turn off:

Press the **Main switch** to turn off.



**NOTE**

*MINI 96 automatically goes into stand-by after 30 minutes of inactivity. Press **OK** to continue.*

### 4.2 Attaching and removing GripTips



**CAUTION**

Use only GripTips in boxes designated for benchtop pipetting systems, see “8.2 Consumables” on page 53 that fit to the **Base stage** and allow supported Griptip loading.

*To prevent contamination of MINI 96 pipetting unit, it is recommended to use filtered GripTips only.*

#### 4.2.1 Loading tips from a rack with 96 tips

Insert the **Base stage** on the **Deck** (2). The graphic “96” must point upwards and match the tip rack pattern (“96” for 300 µl and 1250 µl devices). Put a tip rack on the **Base stage**. Hold the **Control unit** (6) and lower the **Pipetting unit** (8) down onto the tip rack until you are prompted to press **OK** to start automated tip loading.

#### 4.2.2 Loading tips from a rack with 384 tips

12.5 µl and 125 µl tips are available in racks of 384 tips. With a 96 channel head you can load tips four times from these racks, drastically reducing plastic waste. Insert the **Base stage** on the **Deck** with side “384” pointing upwards. Put a tip rack on the **Base stage**.

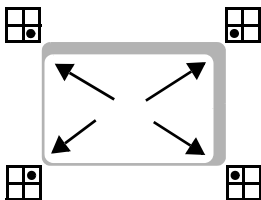

Move the tip rack to one corner, e.g. to the front left to load the back left quadrant. Hold the **Control unit** (6) and lower the pipetting unit down onto the tip rack and load tips by pressing **OK**.

Load the other quadrants in any order.

### 4.2.3 Partially tips loading

Partial tip loading requires the optional Two position stage, see [8.1 "Accessories" on page 52](#).



Place a rack on either the left or right position, and slide the two position stage to underneath the pipetting unit to correspond to the desired number of columns loaded.

The **Stage slider** (b) is used to index the formats:

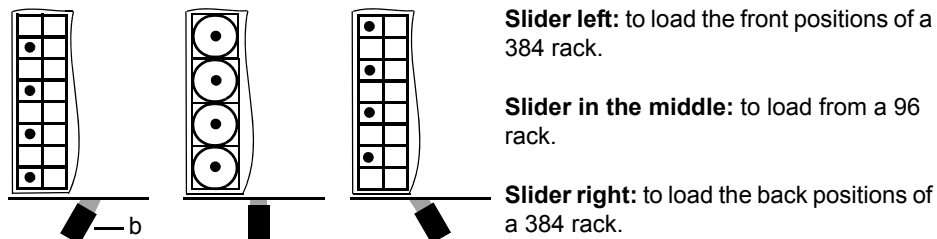

Lower the **Pipetting unit** (8) down until you are prompted to load tips. Press **Partial ▶** and **Set No. of Columns ▶** to enter the number of columns to be filled with tips and press **OK**. Start automated partially tips loading with **OK**.



#### NOTE

*The device adapts the tip loading strength to the number of tips.*

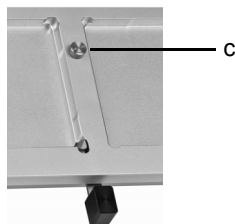

The Two position stage can be moved step by step sideways, corresponding to the 12 or 24 columns of a 96 or 384 well plate, respectively.

Adjust the strength of the sliding guidance by turning the screw (c) in + or - direction.

#### 4.2.4 Ejecting used GripTips

If liquid is in the tips, empty them by pressing **PURGE** (18). Tips are ejected by pressing the **Tip ejector** (20). Confirm ejection by pressing the **Tip ejector** a second time.

### 4.3 Start pipetting

#### 4.3.1 Pipetting

Use the **Touch wheel** (15) to scroll to your desired program and press **OK**.

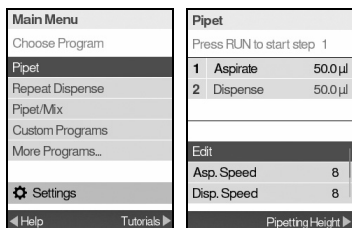

Actions you are about to perform are displayed on the upper half of the respective program screen.

Insert the tips into the liquid to be transferred. Press and release **RUN** to aspirate the volume defined in the first step (highlighted orange).

To execute subsequent steps, press **RUN**. For a detailed description of all programs see [“5.2 Detailed description of programs” on page 31](#).

All parameters of your program are listed with green color in the lower half of the program screen. You can change these parameters any time. Highlight a parameter with the **Touch wheel** and press **OK**. For more details, see the following sections.

#### 4.3.2 Setting pipetting height

To define the lowest possible pipetting height of a program, for example the bottom of a well plate, select **Pipetting Height** ►.

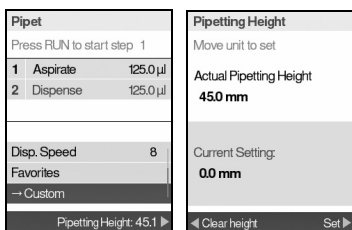

With tips attached move the **Pipetting unit** down to the desired pipetting height.

Press **Set** ► to save your setting.

### 4.3.3 Blowout/blowin modes

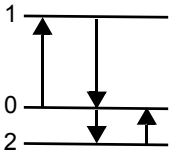

During aspiration, the piston of your electronic pipette moves up (1).

During dispensing, the piston returns to the initial position (0). During the last dispense of a program, it automatically moves further down (2) and blows the remaining liquid from the tip (Blowout↓).

When the piston returns to the initial position (0), a small amount of air is aspirated, provided the tip is no longer immersed in the liquid (Blowin↑).

There are two ways in which the blowin occurs:

- **Manually controlled blowin** (recommended): Perform this routine to manually delay the blowin:
  - Press and hold **RUN** to start dispense with blowout.
  - Remove the tips from the target vessel.
- **Automatic blowin**: Pressing (and releasing) **RUN** starts the dispense with automatic blowout and blowin. You can choose a timed delay between the blowout and the blowin, see “Pipetting - Delayed blowin” under “3.4.2 Preferences” on page 15.

#### 4.3.4 Recommendations for pipetting

INTEGRA Biosciences recommends the following techniques for enhancing pipetting results. These techniques are consistent with ISO standard 8655-2.

- It is best to immerse the GripTips just enough in liquid to allow the desired volume to be aspirated.
- Always pre-wet GripTips. After loading tips onto your pipette, aspirate and dispense the full volume 2-3 times to coat the inside of pipet tips. Pre-wetting ensures that the liquid and air inside the tips are at equal temperature and the dead air space is humidified.
- MINI 96 is an air displacement pipette. It requires to touch the GripTips against the side of the well or dip them into the liquid after a dispense. This process is referred to as “touching off” or “tip touch” and prevents liquid from clinging to the pipette tips.
- In programs such as Repeat Dispense, a pre- and post-dispense can be programmed. These two dispenses are not used and are dispensed into the waste as they contain the accumulated pipetting errors. Using a pre- and post- dispense is recommended if accuracy and precision are of high importance.
- Viscous samples should be aspirated and dispensed at the slowest speeds to ensure accurate pipetting. In addition, the program “Reverse pipet” can be used to optimize pipetting results with viscous samples.
- For pipetting liquids with high vapor pressures (such as methanol or ethanol), use relatively fast pipetting speeds and avoid prolonged pauses after aspiration.
- Calibrate based on fluid type. MINI 96 is tested and calibrated at the factory for use with distilled water at room temperature. It may be necessary to re-calibrate your MINI 96 if the liquid to be used has different physical properties (specific gravity and vapor pressure) than water. Calibration mode can be accessed in the Settings menu.
- MINI 96 is not calibrated out of the factory below 10% of its maximum volume. While it is possible to pipette below 10% of the maximum volume, it may lead to an undesirable precision and accuracy result. Therefore, if accuracy and precision are critical, it is recommended to work above 10% of the pipette’s maximum volume.



### 4.3.5 Pipetting between 96-384 well plates

For fast and simple reformatting between 96 and 384 well microplates insert the **Base stage** on the **Deck (2)** with side “96” pointing upwards. Place a 96 well plate on the **Base stage** and aspirate liquid from the plate. Exit from the liquid and remove the plate.

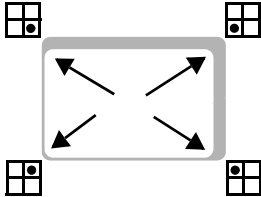

Flip the **Base stage** to “384” format and place a 384 well plate on the **Base stage**.

Move the plate to any corner and dispense liquid, e.g. to the front left to dispense the back left quadrant.



**NOTE**

*The plate movement on the **Base stage** defines the order on the 384 well plate.*

### 4.3.6 Pipetting with the Two position stage

Filling partial plates or performing serial dilutions is easy using the optional Two position stage (see “8.1 Accessories” on page 52). Load as many GripTips as needed.

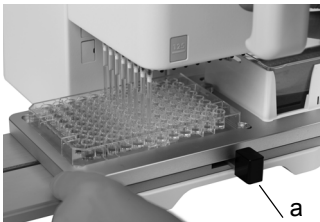

Move the **Stage slider (a)** to the middle to pipette 96 well plates.

Move the Two position stage sideways until the tips are above the center of the wells. Start pipetting.

The sliding of the plate left or right is guided in 12 steps. This strength can be adjusted by turning the screw on located in the middle of the stage, see 4.2.3.

Use **Stage slider (a)** to pipette 384 well plates and to index the formats.

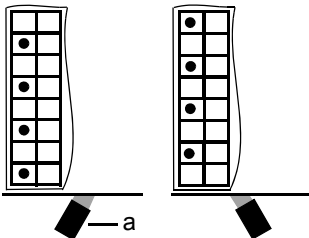

**Slider left:** pipette the front positions of a 384 well plate, sliding of 24 columns is guided.

**Slider right:** pipette the back positions 384 well plate, sliding of 24 columns is guided.

## 4.4 Pipetting options and settings

### 4.4.1 Edit option

The Edit option is available for each program. It enables you to access the variables that you can adjust for a program. These variables include Speed, Volume, Pace, Count, Mix Cycles, Rows and Direction. Additional steps include Pre-Dispense, Post-Dispense, Air Gap, Aspirate Speed, Dispense Speed, etc..

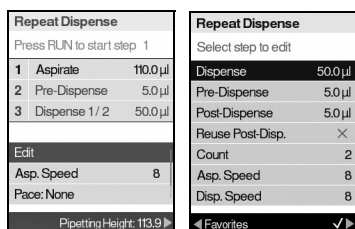

Select a program. Then, select Edit and press **OK**. A list of associated steps is displayed.

For example, if selecting Edit on the Repeat Dispense screen, the modifiable steps are displayed.

### 4.4.2 Volume selection

To change a volume select the Edit option and press **OK**. The adjustable volumes are displayed.

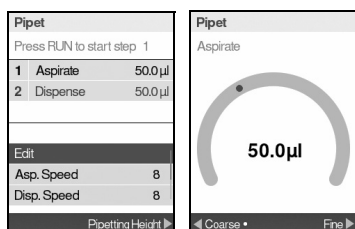

Use the **Touch wheel** to highlight the volume you want to change (Aspirate, Dispense, Mix, or Air Gap).

Press **OK**. A Volume setting dial is displayed.

Use the **Touch wheel** to change the volume. Press **OK** to confirm your volume selection and **►** to save.



#### NOTE

Use the arrow buttons to change the volume in coarse or fine increments. Select **◀ Coarse** to change the volume in larger increments. Select **Fine ▶** to change the volume in smaller increments. The increment sizes vary based on the pipetting unit, as shown under “7.4 Pipetting specifications” on page 50.

### Define and select favorite volumes

You can define up to ten favorite volumes for quick access. These volumes can only be within the pipetting unit volume range.

There are two ways to access and customize the list of favorite volumes:

- When in Pipet program, use the **Touch wheel** to highlight Favorites and press **OK**.

- When in other programs, select the Edit option and press **OK**. The steps with volumes to be adjusted are displayed. Use the **Touch wheel** to highlight the desired volume and press **◀ Favorites** to display the list of favorite volumes.

Pipet	
Favorite Volumes	
Volume 1	125.0 µl
Volume 2	100.0 µl
Volume 3	75.0 µl
Volume 4	60.0 µl
Volume 5	50.0 µl
Volume 6	40.0 µl
Volume 7	30.0 µl
◀ Edit	Select ▶

Pipet	
Volume 1	
125.0 µl	
◀ Coarse •	Fine ▶

Use the **Touch wheel** to highlight the desired volume and press **Select ▶**. Alternatively, modify a volume by pressing **◀ Edit**.

Save your setting **▶**.

### 4.4.3 Speed selection

The speed option controls the speed at which liquid is aspirated, dispensed, or mixed in each program. Speed can be set as a value from 1 (slowest) to 10 (fastest).

Pipet	
Press RUN to start step 1	
1 Aspirate	125.0 µl
2 Dispense	125.0 µl
Edit	
Asp. Speed	8
Disp. Speed	8
Pipetting Height: 45.1 ▶	

Pipet	
Asp. Speed	
8	

When in any program, use the **Touch wheel** to highlight the Speed option and press **OK**. Select the speed and press **OK** to save your setting.

Sample Dilute	
Press RUN to Start Step 1	
1 Aspirate	75.0 µl
2 Air Gap	5.0 µl
3 Aspirate	15.0 µl
Edit	
Asp. Speed	8
→ Custom	
Pipetting Height: 113.9 ▶	

Sample Dilute	
Select step to edit	
Aspirate 1	75.0 µl
Air Gap	5.0 µl
Aspirate 2	15.0 µl
Asp. Speed	8
Disp. Speed	8
◀ Favorites	

Sample Dilute	
Asp. Speed	
8	

Speed may be changed in most Edit menus.

Scroll to the Speed and press **OK**. Choose the speed, press **OK**, and press **▶** to save your selection.

The speeds selected in each program (i.e., Pipet, Repeat Dispense, etc.) are stored for that program only.

Speeds can be set independently for each operation (Aspirate, Dispense, Mix).



#### NOTE

*Viscous samples should be aspirated and dispensed at the slowest speeds to ensure accurate pipetting.*

*To dispense liquids with low viscosity and high vapor pressure, such as ethanol, use relative fast pipetting speeds and avoid prolonged pauses for aspiration.*

#### 4.4.4 Pace

The Pace option sets the time gap between repeat dispenses. Pace is used in the Repeat Dispense and Variable Dispense programs. While you press and hold **RUN**, the pipette will dispense multiple programmed volumes with the selected pace. Release **RUN** to stop the paced dispense. Press **RUN** to continue dispensing.

Repeat Dispense	
Press RUN to start step 1	
1 Aspirate	110.0 µl
2 Pre-Dispense	5.0 µl
3 Dispense 1 / 2	50.0 µl
Asp. Speed 8	
Pace: None	
→ Custom	
Pipetting Height: 113.9 ▶	

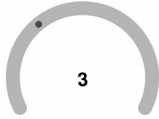
Repeat Dispense	
Pace	
	
3	

Use the **Touch wheel** to select the desired Pace option and press **OK**.

Select the pace, from None, 1 (slowest) to 9 (fastest). Press **OK** to save your setting.

#### 4.4.5 Count, Mix Cycle and Rows

The Count, Mix Cycle, and Rows steps are used in various programs, see [“5.2 Detailed description of programs” on page 31](#). Each is accessed with the Edit option. Use the **Touch wheel** to highlight the step and press **OK**.

Select a desired value. Press **OK** and then press ▶ to save your setting(s).

#### 4.4.6 Custom

You can convert any predefined program into a Custom program.

Pipet	
Press RUN to start step 1	
1 Aspirate	125.0 µl
2 Dispense	125.0 µl
Disp. Speed 8	
Favorites	
→ Custom	
Pipetting Height: 45.1 ▶	

Custom Programs																																									
Enter Name																																									
TESTI																																									
<table border="0"> <tr><td>A</td><td>B</td><td>C</td><td>D</td><td>E</td><td>F</td><td>G</td><td>H</td><td>I</td><td>J</td></tr> <tr><td>K</td><td>L</td><td>M</td><td>N</td><td>O</td><td>P</td><td>Q</td><td>R</td><td>S</td><td>T</td></tr> <tr><td>U</td><td>V</td><td>W</td><td>X</td><td>Y</td><td>Z</td><td>-</td><td>µ</td><td></td><td></td></tr> <tr><td>0</td><td>1</td><td>2</td><td>3</td><td>4</td><td>5</td><td>6</td><td>7</td><td>8</td><td>9</td></tr> </table>		A	B	C	D	E	F	G	H	I	J	K	L	M	N	O	P	Q	R	S	T	U	V	W	X	Y	Z	-	µ			0	1	2	3	4	5	6	7	8	9
A	B	C	D	E	F	G	H	I	J																																
K	L	M	N	O	P	Q	R	S	T																																
U	V	W	X	Y	Z	-	µ																																		
0	1	2	3	4	5	6	7	8	9																																
◀ Delete	Save ▶																																								

After setting up a program with your parameters, use the **Touch wheel** to select ▶ Custom.

You are prompted to enter a name. Use the **Touch wheel** to select characters and press **OK**. Once finished, press ▶ to save the name.

The program is now stored in the Custom program section.

## 4.5 Troubleshooting/FAQ

<b>Problem</b>	<b>Probable cause</b>	<b>Remedy</b>
Pipetting unit is drifting up/down.	Control unit was touched at switch on.	Do not touch the control unit when switching on the MINI 96. Restart MINI 96 to initiate new homing routine.
Touch wheel does not work properly.	Control unit was touched during homing.	Do not touch the control unit during homing. Restart MINI 96 to initiate new homing routine.
Tips cannot be loaded.	Pipetting height defined too high above the top of the tip rack.	You have 3 possibilities: <ul style="list-style-type: none"> <li>• Enable “Pipetting Height Override” under Settings - Position settings. To override the defined pipetting height keep pushing down the pipetting unit for a short time.</li> <li>• Exit pipetting program and load tips.</li> <li>• Clear pipetting height.</li> </ul>
Droplets on the tips.	Temperature of liquid differs from that of air inside the tips.	Pre-wet tips up to 3 times.
	Liquid of low viscosity and high vapor pressure.	Pre-wet tips and increase dispensing speed.
	Touch-off was not performed.	Perform a touch-off (mandatory in Repeat Dispense and Variable Dispense program).

## 5 Programs

This chapter describes how to program the MINI 96 in two ways:

- **Function-based programs:** You can select from ten predefined programs that you can quickly and easily edit and execute. They are described in the following sections.
- **Custom step-based programming program:** You can create and store multi-stepped pipetting protocols on the pipette using the basic functions presented in “5.2 Detailed description of programs” on page 31. How to create a custom program is described in “5.3 Custom step-based program” on page 42.

### 5.1 Overview programs

The first four programs are listed in the main menu by default. In the Settings you can define which programs are visible in the Main Menu, and which are located in More Programs. Use the **Touch wheel** to scroll to your desired program.

Program	Description
Pipet	Allows liquid transfers when aspirate and dispense volumes are equal.
Repeat Dispense	Allows dispensing multiple aliquots of the same volume without refilling the tips after each dispense for fast microplate filling and processing.
Pipet/Mix	Transfers a defined volume and follows with a defined number of automatic mixing cycles.
Custom Programs	Allows to create and store of up to 40 multi-stepped pipetting protocols.
<b>More Programs...</b>	
Sample Dilute	Allows aspirating of sample and diluent divided by a defined air gap into one tip, followed by a complete dispense.
Manual Pipet	Allows the operator to manually control the aspiration and dispensing up to the set volume.
Reverse Pipet	Allows liquid transfers of viscous or high vapor pressure liquids by preventing introduction of any air into the sample. The aspiration volume is higher than the volume to be dispensed.
Variable Dispense	Allows dispensing multiple aliquots of different volumes.
Multi Aspirate	Allows aspirating multiple aliquots of different volumes.
Sample Dilute/Mix	Allows aspirating two liquids separated by an air gap followed by a complete dispense and mix step.
Serial Dilution	Allows aspirating a transfer volume followed by a mix. Rows and mix cycles are tracked on the display.

Press the **OK** to access the program and to start defining parameters. Press **◀** to select the Help option.

## 5.2 Detailed description of programs

MINI 96 offers ten predefined programs. Most liquid handling protocols can be easily accommodated using one or more of these programs. The options and steps of the different programs are described in the following subsections.

### 5.2.1 Pipet



**Application:** Use this program for quick transfer of liquid to or from microplates.

To easily reformat plates, put the 384 well plate on the **Base stage**. Aspirate from the 96 well plate on the **Second stage** and dispense into the 384 well plate. If no **Second stage** is available, use and flip the **Base stage** see “4.3.5 Pipetting between 96-384 well plates” on page 25.

Run steps	Operation
Aspirate	With the tip(s) in liquid, press and release <b>RUN</b> to aspirate.
Dispense	With the tip(s) in the target plate, press and hold <b>RUN</b> to execute the dispense and perform a two-step blowout, see 4.3.3. When the tips are removed from the target plate, release <b>RUN</b> .

The following parameters can be changed at any time:

Options	Description
Edit	Sets the aspiration volume that is equal to the dispense volume.
Asp. Speed	Sets speed for aspiration (1 = low, 10 = fast).
Disp. Speed	Sets speed for dispensing (1 = low, 10 = fast).
Favorites	Defines up to 10 favorite volumes.
→ Custom	Converts the predefined program into a custom program.

### 5.2.2 Repeat Dispense



**Application:** This program can be used for fast reagent addition to microplates from one source container. You can dispense a large aspirated volume of liquid in multiple aliquots to multiple targets.

To easily fill micro plates, put the reservoir on the **Base stage**. Aspirate the desired volume and dispense in the 96 well microplate placed on the **Second stage**. Replace the 96 well plates for the following dispenses.

Run steps	Operation
Aspirate	With the tip(s) in liquid, press and release <b>RUN</b> to aspirate the calculated volume.
Pre-Dispense	Press and release <b>RUN</b> to dispense and discard the pre-dispense volume.
Dispense 1/Count	Press and release <b>RUN</b> for every dispense. Alternatively, press and hold <b>RUN</b> to execute paced dispenses. The dispense number is shown on the display. The pipette will stop paced dispenses when it reaches the last dispense or Post-Dispense step, if defined. If no Post-Dispense volume is defined, <u>press and hold</u> <b>RUN</b> to purge the last dispense volume with a two-step blowout.
Post-Dispense	You can choose to discard this Post-Dispense or use it. <u>Press and hold</u> <b>RUN</b> to purge the Post-Dispense volume with a two-step blowout. If reuse of last dispense is active, the Post-Dispense remains in the tip. Press <b>RUN</b> to go to the aspirating step of the next repeat dispense cycle. The aspirating volume will be reduced by the volume of the Post-Dispense in the tip. To finish the repeat dispense cycle, press <b>PURGE</b> .



The following parameters can be changed at any time:

Options	Steps	Description
Edit	Dispense	Sets the volume for repetitive dispensing. The aspirated volume is calculated automatically.
	Pre-Dispense	A pre-dispense volume (typically 3-5% of the pipette's maximum volume) can be selected independently to improve accuracy and precision. The dispense is discarded.
	Post-Dispense	A post-dispense volume (typically 3-5% of the pipette's maximum volume) can be selected independently to improve accuracy and precision. The dispense is discarded.
	Reuse Post-Disp.	By default (red ✖), the program ends with dispensing of the post dispense. This aliquot contains the accumulated error from all prior dispenses. If you want to reuse the post dispense, press <b>OK</b> (green ✓). At the end of the program the post dispense remains in the tip, while the pipette is ready to aspirate a new volume to start the next repeat dispense run.
	Count	The maximum number of dispenses possible (count) is calculated automatically. This count may be reduced to the desired number.
	Asp. Speed	Sets speed uniquely for aspirating (1 = slow, 10 = fast).
	Disp. Speed	Sets speed uniquely for dispensing (1 = slow, 10 = fast).
Asp. Speed Disp. Speed		Sets speed of the current pipetting step.
Pace		Sets the time duration between dispenses in repeat pipetting, if keeping <b>RUN</b> pressed (None, 1 = long, 9 = short).
→ Custom		Converts the predefined program into a custom program.

### 5.2.3 Pipet/Mix



**Application:** Use this program when mixing is required immediately after transfer of liquid. This program saves a programming step by incorporating the mix option after dispensing.

Run steps	Operation
Aspirate	Press and release <b>RUN</b> to initiate the aspiration.
Dispense Mix	Press and release <b>RUN</b> to dispense. Mixing occurs automatically after the dispense step.
Remove tips	Upon completing the desired number of mixes, a blowout is performed automatically. You are prompted to remove the tip(s) from the liquid and to press <b>RUN</b> to start the blowin.

The following parameters can be changed at any time:

Options	Steps	Description
Edit	Aspirate	Sets the aspiration volume that is equal to the dispense volume.
	Mix	Sets the mixing volume after dispensing.
	Mix Cycles	Sets the number of mix cycles.
	Asp. Speed	Sets speed uniquely for aspirating (1 = slow, 10 = fast).
	Mix Speed	Sets speed uniquely for mixing (1 = slow, 10 = fast).
Asp. Speed Disp./Mix Speed		Sets speed of the current pipetting step.
→ Custom		Converts the predefined program into a custom program.

### 5.2.4 Sample Dilute



**Application:** Accomplish accurate sample dilutions by using diluent to chase small sample volumes from the pipet tips. An air gap keeps liquid separated in the tips and helps to minimize carryover of diluent when aspirating the sample.

Run steps	Operation
Aspirate	Press and release <b>RUN</b> to initiate each aspiration
Air Gap	Remove tips from liquid for air-gap aspiration and press <b>RUN</b> .
Dispense	<u>Press and hold <b>RUN</b></u> to perform a two-step blowout. The entire tip contents will be dispensed together. Remove the tip(s) from the liquid and release <b>RUN</b> for blowin.

The following parameters can be changed at any time:

Options	Steps	Description
Edit	Aspirate 1	Sets the volume of the diluent aspirated first in the tip.
	Air Gap	Sets the volume of the air gap to keep both liquids separated.
	Aspirate 2	Sets the volume of the sample in the tip.
	Asp. Speed	Sets speed uniquely for aspirating (1 = slow, 10 = fast).
	Disp. Speed	Sets speed uniquely for dispensing (1 = slow, 10 = fast).
Asp. Speed Disp. Speed		Sets speed of the current pipetting step.
→ Custom		Converts the predefined program into a custom program.

### 5.2.5 Manual Pipet



**Application:** This program can be used when the aspiration volume is not defined or unknown. You have control over the aspiration and dispense steps and can view the display to confirm how much liquid has been aspirated or dispensed. Manual control over the dispense steps is perfect for performing titrations.

Run steps	Operation
Aspirate	Press <b>and hold</b> <b>RUN</b> for aspiration. The motor will stop when you release <b>RUN</b> or when the programmed aspirate volume is reached. The actual volume in the tip(s) is displayed.
Dispense	When the defined volume is aspirated press <b>RUN</b> to start dispense.
	To dispense if the aspiration volume is not reached, use the <b>Touch wheel</b> to highlight the direction option. Press <b>OK</b> to switch from Aspirate ▲ to Dispense ▼.



**NOTE**

*Use slower pipetting speeds (1-5) for better control and resolution.*

The following parameters can be changed at any time:

Options	Steps	Description
Edit	Aspirate	Sets the aspiration or dispensing volume. Toggle between Aspirate and Dispense using the Direction menu option.
Asp. Speed Disp. Speed		Sets speed of the current pipetting step (1 = slow, 10 = fast).
Aspirate ▲ Dispense ▼		Changes the direction of pipetting between aspiration and dispensing.
Favorites		Defines up to 10 favorite volumes

### 5.2.6 Reverse Pipet



**Application:** With this program the aspiration volume is higher than the volume dispensed. It is recommended for liquid transfers of viscous and high vapor pressure liquids. The dispense method prevents introduction of air into the sample because no blowout is made.

Run steps	Operation
Aspirate	Press and release <b>RUN</b> to initiate the aspiration. The total volume aspirated is the sum of desired dispense volume and last dispense volume.
Dispense	Press and release <b>RUN</b> to dispense the programmed volume.
Post-Dispense	If reuse of last dispense is not activated, <u>press and hold</u> <b>RUN</b> to purge the Last Dispense volume with a two-step blowout.
	If reuse of last dispense is active, you can start the next reverse pipet cycle with aspirating liquid to the last dispense in the tip. To finish the reverse pipet cycle, press <b>PURGE</b> .

The following parameters can be changed at any time:

Options	Steps	Description
Edit	Dispense	Sets the dispense volume.
	Post-Dispense	Sets the volume to leave in the tip until final blowout.
	Reuse Post-Disp.	By (red ✖) default, the program ends with dispensing of the last dispense. If you want to reuse the last dispense, press <b>OK</b> (green ✓). At the end of the program the last dispense remains in the tip, while the pipette is ready to aspirate a new volume to start the next reverse pipet run.
	Asp. Speed	Sets speed uniquely for aspirating (1 = slow, 10 = fast).
	Disp. Speed	Sets speed uniquely for dispensing (1 = slow, 10 = fast).
Asp. Speed Disp. Speed		Sets speed of the current pipetting step.
→ Custom		Converts the predefined program into a custom program.

### 5.2.7 Variable Dispense



**Application:** Use this program when differing dispense volumes are required. This program could be used to quickly set up a dilution series in plates or for feeding similar samples to different assay plates where different sample volumes are needed.

Run steps	Operation
Aspirate	Press and release <b>RUN</b> to initiate the aspiration of total volume.
Pre-Dispense	Press <b>RUN</b> to discard the defined volume.
Dispense 1/Count	Press and release <b>RUN</b> to initiate each subsequent dispense. Alternatively, <u>press and hold RUN</u> to execute paced dispenses. If no Post-Dispense volume is defined, <u>press and hold RUN</u> during the last dispense to perform a two-step blowout.
Post-Dispense	The pipette stops when ready for the Post-Dispense step, i.e. to purge the calculated waste volume amount. This aliquot contains the accumulated error from all prior dispenses. <u>Press and hold RUN</u> to discard the defined volume with a two-step blowout.

The following parameters can be changed at any time:

Options	Steps	Description
Edit	Count	Sets the total number of dispensing steps.
	Dispense 1...Count	Sets different volumes for repeated dispensing. Number of dispenses and dispense volume cannot exceed nominal volume of the pipetting unit. The total volume is automatically calculated.
	Pre-Dispense	A pre-dispense volume can be selected independently to improve accuracy and precision. The dispense is discarded.
	Post-Dispense	A post-dispense volume can be selected independently to improve accuracy and precision. The dispense is discarded.
	Asp. Speed	Sets speed uniquely for aspirating (1 = slow, 10 = fast).
	Disp. Speed	Sets speed uniquely for dispensing (1 = slow, 10 = fast).
Asp. Speed Disp. Speed		Sets speed of the current pipetting step.
Pace		Sets the time interval between dispenses, if keeping <b>RUN</b> pressed (None, 1 = long, 9 = short).
→ Custom		Converts the predefined program into a custom program.

### 5.2.8 Multi Aspirate



**Application:** This program can be used for a variety of collection applications where the aspiration volume is well known. This program is also suited for supernatant collection in microplates.

Run steps	Operation
Aspirate 1/Count	With the tip(s) in liquid, press and release <b>RUN</b> to initiate the first aspiration volume. Again in liquid, press and release <b>RUN</b> to initiate the second aspiration volume, etc.
Dispense	<u>Press and hold</u> <b>RUN</b> to start Dispense and perform a two-step blowout.

The following parameters can be changed at any time:

Options	Steps	Description
Edit	Count	Sets the total number of aspirating steps.
	Aspirate 1...Count	Sets different volumes used for sequentially aspirating (in the same tip) followed by a single dispense. Number of aspirates and aspirate volume cannot exceed nominal volume of the pipette.
	Asp. Speed	Sets speed uniquely for aspirating (1 = slow, 10 = fast).
	Disp. Speed	Sets speed uniquely for dispensing (1 = slow, 10 = fast).
Asp. Speed Disp. Speed		Sets speed of the current pipetting step.
→ Custom		Converts the predefined program into a custom program.

### 5.2.9 Sample Dilute/Mix



**Application:** Use this program to perform sample dilutions where mixing of sample and diluent is required. This program could also be used to introduce and mix diluent and sample to the first column of a serial dilution plate.

Run steps	Operation
Aspirate	With the tip(s) in liquid, press and release <b>RUN</b> to initiate the first aspiration.
Air gap	With the tip(s) out of the liquid, press and release <b>RUN</b> for the Air Gap.
Aspirate	Again in liquid, press and release <b>RUN</b> to initiate the second aspiration.
Dispense Mix	Press and release <b>RUN</b> to dispense the entire tip contents and begin the mixing routine. Upon completing the desired number of mixes, a blowout occurs automatically. Remove tips from liquid and press and release <b>RUN</b> to start the blowin.

The following parameters can be changed at any time:

Options	Steps	Description
Edit	Aspirate 1	Sets the volume of the diluent aspirated first in the tip.
	Air Gap	Sets the volume of the air gap to keep both liquids separated.
	Aspirate 2	Sets the volume of the sample in the tip.
	Mix	Sets the mixing volume after dispensing.
	Mix Cycles	Sets the number of mix cycles.
	Asp. Speed	Sets speed uniquely for aspirating (1 = slow, 10 = fast).
	Mix Speed	Sets speed uniquely for mixing (1 = slow, 10 = fast).
Asp. Speed Disp. Speed		Sets speed of the current pipetting step.
→ Custom		Converts the predefined program into a custom program.



### 5.2.10 Serial Dilution



**Application:** Use this program to perform serial dilutions. The program enables aspiration of a specific volume followed by a mix sequence and ending with the original aspiration volume in the tips.

The Two position stage is required to perform serial dilutions, see “[4.3.6 Pipetting with the Two position stage](#)” on page 25.

Run steps	Operation
Aspirate	Attach 8 GripTips on the leftmost row. Put a reagent reservoir on the right side of the <b>Two position stage</b> . Press and release <b>RUN</b> to initiate the aspiration of the reagent.
Mix [Mix Cycles] (n/Rows)	Put a micro plate on the left side of the <b>Two position stage</b> . Press and release <b>RUN</b> to start the dispense and mix sequence. Proceed with the next rows. Mix Cycles are tracked in orange on the top of the display. The actual row (first number) and the defined number of Rows (second number) are also tracked.
Dispense	<u>Press and hold <b>RUN</b></u> to start Dispense and perform a two-step blowout.

The following parameters can be changed at any time:

Options	Steps	Description
Edit	Aspirate	Sets the aspiration volume that is identical to the dispense volume.
	Mix	Sets the mixing volume after dispensing.
	Mix Cycles	Sets the number of mix cycles.
	Rows	Sets the number of rows. A row indicator will notify the number of dilutions performed.
	Asp. Speed	Sets speed uniquely for aspirating (1 = slow, 10 = fast).
	Mix Speed	Sets speed uniquely for mixing (1 = slow, 10 = fast).
	Disp. Speed	Sets speed uniquely for dispensing (1 = slow, 10 = fast).
Asp. Speed Disp. Speed		Sets speed of the current pipetting step.
→ Custom		Converts the predefined program into a custom program.



#### NOTE

For serial dilutions it is helpful to adjust the strength of the sliding guidance of the Two position stage, see “[3.3.3 Two position stage](#)” on page 13.

### 5.3 Custom step-based program

**Application:** Use “Custom Programs” to create personalized pipetting protocols. Programs can contain up to 98 individual steps based upon the following basic operations: Aspirate, Dispense, Mix, Purge, Prompt, Pipetting Height and Loop.

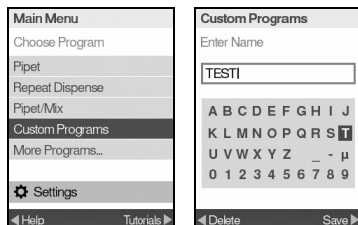

Press **New** ► to create a new program.

You are prompted to enter a name.

Use the **Touch wheel** to select characters and press **OK**. Once finished, press ► to save the name.

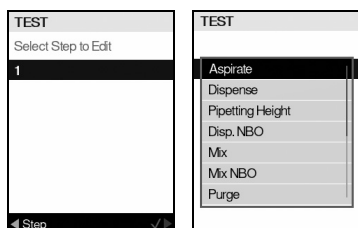

The first step is highlighted, press **OK**.

Use the **Touch wheel** to select the first step from the menu, e.g. Aspirate. Press **OK**. Define the required parameters and press **OK** to add the step.

After adding the first step, the selection should now be on the second line. Press **OK** again to define the second step. Continue adding steps until your entire pipetting protocol is defined.

#### 5.3.1 Program steps

Custom programs can consist of the following steps:

Step	Description
Aspirate	Sets an aspiration volume and speed.
Dispense	Sets a dispense volume and speed.
Pipetting Height	Sets the pipetting height.
Disp. NBO (No BlowOut)	Sets the volume and speed for a dispense without blowout. Residual liquid may remain in the tip, resulting in inaccurate and imprecise liquid delivery. Select this step only if accuracy and precision are not important.
Mix	Sets the mixing volume after dispensing.

Step	Description
Mix NBO (No BlowOut)	Sets the mixing volume and speed without a blowout after the last dispense. Residual liquid may remain in the tip, resulting in incomplete mixing and inaccurate and imprecise liquid delivery. Select this step only if introduction of air into the sample must be prevented.
Purge	Purges all remaining liquid currently in the GripTips with the selected purge speed. A “Purge” step is automatically integrated at the end of a program if the last programming step leaves liquid in the tips.
Prompt	A prompt is any message that is displayed during the program. Three lines with a total of 45 characters are available. To continue the program, press <b>RUN</b> .
BlowOut	Performs a blowout. A blowout needs to be performed after the last dispense to expel residual liquid. Note: When using a standard “Dispense” step or “Purge”, a blowout/blowin is performed automatically to empty the tips and does not need to be programmed.
Blowin	If a BlowOut step was added, it needs to be followed directly with a BlowIn. It brings the piston(s) back to the home position. Make sure to remove the tips from the liquid before starting the BlowIn.
Timer	Sets a timer from 0 s to 60 min. When the count down is finished, the next step is performed automatically. If under Preferences - Sounds the option Messages is set to On a beep tone sounds.
Loop	A loop repeats the steps between the selected step and the loop command.  Chose to which step the loop directs and how many times the loop should be performed.  The number of steps can often be shortened by adding a loop. Note: Nested loops (loops inside loops) are not allowed.
Beep	Sets a beep. The sound is only active, if under Preferences - Sounds the option Messages is set to On.

When starting with an “Aspirate” step followed by a “Mix” step, the tips contain the aspirate volume after completing the last mix cycle. When starting with a “Mix” step, the tips are emptied upon completion of the last mixing cycle.

To save and store a Custom program, press ►.

### 5.3.2 Modify existing programs

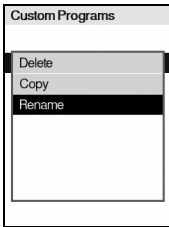

At the Custom program display, use the **Touch wheel** to highlight an existing program. Press ◀ Options, use the **Touch wheel** to select an option (Delete, Copy, Rename) to modify the program and press **OK**.

Press the **Back button** to return to the list of Custom programs. To run the program, press **OK**.

## 6 Maintenance



### **WARNING**

*Always turn off power and disconnect the MINI 96 from the mains when carrying out maintenance work.*

### 6.1 Cleaning

The materials used on the exterior of the MINI 96 support regular cleaning intervals. Clean the external components and stages with a lint-free cloth lightly soaked with mild soap solution in distilled water or with a 70 % dilution of Isopropyl or Ethanol. Never use acetone or other solvents.

### 6.2 Decontamination

If the surfaces of the MINI 96 have been in contact with biohazardous material, they must be decontaminated in accordance to good laboratory practice. Wipe the clean instrument surface with a lint-free cloth, lightly soaked e.g. with the following disinfectants:

- Ethanol 70%
- Microcide SQ 1:64
- Glutaraldehyde solution 4%
- Virkon solution 1-3%

Follow the instructions provided with the disinfectants.

#### 6.2.1 Two position stage

The Two position stage can also be cleaned the same way as the MINI 96. However, for a more thorough cleaning or autoclaving, disassemble according to the instructions below:

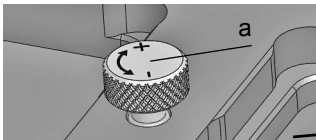

- Unscrew the spring adjustment screw (a) all the way to the upper limit.

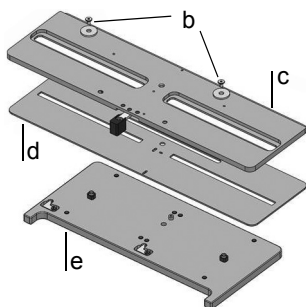

- Place the Two position stage on a table with the bottom side up and remove the two screws and washers (b) with a Torx 10 screwdriver.
- Hold the position sheet (c) and the guide sheet (d) together and remove them from the nest (e).
- Remove the position sheet (c) from the guide sheet (d).

All the internal parts are now accessible for cleaning.

Place the disassembled components inside an autoclave pouch. You may autoclave the components at 121°C, 1 bar overpressure for 20 minutes.

Reassemble by following these instructions in reverse. If any small parts get lost, a spare parts bag is available, see [“8 Accessories and consumables” on page 52](#).

### 6.3 Leak test

It is recommended to perform a leak test every 3 months or when errors occur.

Leak test may be done with full or half tips loaded, or column by column for a better view of the liquid levels (load one GripTip column with reduced force as described under operation of [“4.2.3 Partially tips loading” on page 21](#)).

- 1) Choose Pipet/Mix program and enter the following settings: aspirate the full volume at speed 6, mix cycles 6 at speed 6.
- 2) Fill a reservoir with distilled water (add some food coloring for better visibility).
- 3) Pre-wet the GripTips: Start the Pipet/Mix program by pressing **RUN**. After aspiration, press **PURGE** and confirm with **RUN**. This empties the tips. Repeat 2 more times to a total of 3 pre-wet cycles.
- 4) Press **RUN** again to aspirate. Leave the tips immersed 2-3 mm in the liquid and observe for 30 s the liquid levels in the tips. During this wait time the liquid levels must not decrease.
- 5) Press **RUN** again to start the mix cycles.
  - a) Observe whether air bubbles are forming at the tip ends when dispensing.
  - b) Check whether the levels stay approximately the same across all channels.
  - c) At the end of a last dispense it is normal to have air bubbles because a blowout is performed.

If in doubt about a particular channel, load a tip on this channel only and repeat the test.

#### Signs indicating a leak

- 1) Liquid level in one or more tips is decreasing while the tips are immersed in liquid during the 30 s wait time.
- 2) During the mix cycle the top aspiration level in one or more tips is gradually decreasing. This shows in uneven liquid levels across the tips after aspiration.
- 3) One or more tips show air bubbles at the tip end during the mix cycles.



#### **NOTE**

*A decreasing liquid level at aspiration could be an indication of a slow leak. Performing a retest at 10 mixes may help identify a slow leak.*

If a leaking channel is identified, change the red O-ring on that specific tip fitting (where applicable, see [6.4.1](#)) or contact your service technician.

## 6.4 Servicing

An annual maintenance service is recommended on the MINI 96 as well as calibration of the pipetting unit in order to ensure optimal pipetting accuracy/precision, as well as a long life for the device. In addition, a complete pipetting unit refurbishment should be performed every 2-3 years to ensure proper function and longevity of the unit.

If you intend to ship the MINI 96 to be periodically calibrated, the original packaging can be stored and reused for this purpose. Contact INTEGRA for more information about available calibration services.

Please contact INTEGRA for more details and pricing information.



### **WARNING**

*If liquid ever enters the internals of MINI 96 of the pipetting unit, please contact your service technician.*

Pipetting unit need to be serviced by INTEGRA in the following cases:

- Liquid has entered the pipetting unit
- One or more channels did not pass the leak test
- The pipetting unit was damaged



### **WARNING**

*If working with infectious materials, e. g. human pathogens, MINI 96 needs to be decontaminated before sending it to service and the declaration on the absence of health hazards must be signed. This is necessary to protect service personnel.*

Before MINI 96 can be shipped, the pipetting unit must be fixed. In the “Settings” menu select “Park Head”, see [“3.4.6 Park Head” on page 18](#). Make sure GripTips have been ejected, clear the **Deck** and press **RUN** (to start the park routine. The unit moves to the park position and is anchored on the base with a bolt. Switch off MINI 96 and disconnect it from the electricity mains.

### 6.4.1 Changing O-rings of tip fittings

300 µl and 1250 µl pipetting unit feature tip fittings with red O-rings to seal against the inside wall of GripTips providing optimal sealing. O-rings are made of durable silicone.

If necessary, e.g. in case of a leakage due to damaged O-rings, you can replace these O-rings. A set of spare O-rings and an O-ring removal tool are included with each 300 µl and 1250 µl pipette, but can also be ordered separately, see [“8.1 Accessories” on page 52](#).



### **WARNING**

*Avoid mechanical damage of the tip fittings.*



Choose the side of the O-ring removal tool corresponding to the size of the pipette (300  $\mu$ l or 1250  $\mu$ l). Slide the O-Ring removal tool sideways onto the tip fitting until the O-ring (a) builds a loop. Cut the O-ring with fine scissors and remove it.

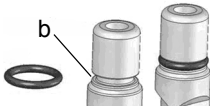

Slide a new O-ring over the tip fitting (b).

## 6.5 Calibration

MINI 96 can be calibrated by adjusting a correction factor in the software. The correction factor is determined by a nominal volume and the measured volume. To assess the accuracy and precision of MINI 96, different methods can be used:

- Measure one or more channels gravimetrically and then all other channels by photometry. Compare the photometrically determined channels relative to the gravimetrically measured channels. Contact INTEGRA for a detailed protocol.
- Gravimetric only.

INTEGRA Biosciences offers a calibration service for MINI 96. Please contact INTEGRA or your local dealer for more information.

## 6.6 Equipment disposal



The MINI 96 must not be disposed of with unsorted municipal waste.

Dispose the MINI 96 in accordance with the laws and regulations in your area governing disposal of devices.





## 7 Technical Data

### 7.1 Environmental conditions

	Operation
Temperature range	5–40 °C
Humidity range	Max. rel. humidity 80 % for temperatures up to 31 °C, decreasing linearly to 50 % rel. humidity at 40 °C.
Altitude range	< 2000 m

### 7.2 Specification of the device

Dimensions (W x D x H)	12.5 µl and 125 µl: 16 cm x 26 cm x 40 cm (6.3" x 10.2" x 15.8") 300 µl and 1250 µl: 16 cm x 26 cm x 44 cm (6.3" x 10.2" x 17.3")
Weight	12.5 µl and 125 µl: 8.8 kg (19.5 lbs) 300 µl and 1250 µl: 9.4 kg (20.7 lbs)
Electricity supply	Mains adapter input: 100–240 VAC, 47–63 Hz Device input: 22.8–25.2 VDC, 100 W
Pipetting channels	96
Pipetting speed	10 steps
Compatible plate formats	96, 384, shallow and deep well
Pipetting technology	Air displacement
User interface	Touch wheel, color display

### 7.3 Intellectual Property

The MINI 96 are covered under the following patents:

Patent Number	Country	Title	Apply to
7,811,522	USA	Sample Reservoir Kits With Disposable Liners	Reservoirs
D599,031	USA	A Liquid Sample Or Liquid Reagent Reservoir Kit	Reservoirs
8,277,757	USA	Pipette Tip Mounting Shaft	GripTips
8,501,118	USA	Disposable Pipette Tip	GripTips

### 7.4 Pipetting specifications

Volume Range (µl)	Min. Scrolling Volume Increments (µl)	Test Volume (µl)	Accuracy (±%)	Precision (≤%)
0.5–12.5	0.01	1.25	8.0	3.0
		6.25	2.0	1.5
		12.5	1.5	1.0
(2 µl–) <sup>1</sup> 5–125	0.1	12.5	3.0	1.7
		62.5	2.0	1.5
		125	1.5	1.0
(5 µl–) <sup>1</sup> 10–300	0.5	30	2.5	1.5
		150	1.5	1.0
		300	1.2	0.8
(25 µl–) <sup>1</sup> 50–1250	1	125	2.5	1.5
		625	2.0	1.0
		1250	1.8	0.8

1. The volumes in brackets refer to extended volumes, see “Pipetting” under “3.4.2 Preferences” on page 15. For the extended range these specifications do not apply.

## 7.5 Pipetting Speeds

Speed	Pipetting Unit Size			
	Pipetting speed (micro litres per second)			
	12.5 µl	125 µl	300 µl	1250 µl
1	0.6	5.2	12.4	49.6
2	1.1	10.4	24.8	99.3
3	2.8	25.9	61.9	248.2
4	3.6	33.7	80.5	322.7
5	4.4	41.5	99.0	397.1
6	5.8	54.0	128.7	516.3
7	8.3	77.8	185.7	744.6
8	10.5	98.6	235.2	943.1
9	11.8	111.0	264.9	1062.3
10	13.1	123.5	294.9	1181.4

The speeds apply to firmware version 1.00 or higher.

## 8 Accessories and consumables

### 8.1 Accessories

<b>Stages and Covers</b>		<b>Part No.</b>
	Two position stage	4850
	Spare parts for Two position stage	129935
	Magnetic covers	4890
<b>O-rings for tip fittings</b>		<b>Part No.</b>
	O-ring removal tool (for 4803 and 4804)	130-00731-00
300 µl	Replacement kit 24 per pack	100-00027-50
300 µl	Replacement kit 100 per pack	125928
1250 µl	Replacement kit 24 per pack	100-00028-50
1250 µl	Replacement kit 100 per pack	125929

## 8.2 Consumables

### GripTips for benchtop pipetting systems are suitable for MINI 96.

These GripTips are straightness tested and filled in sturdy racks.

- GREEN CHOICE: environmentally friendly refills
- LONG: longer design allows easy access into deep laboratory vessels
- SHORT: shorter design
- low retention: low liquid retention, for liquids with low surface tension
- WIDE BORE: large opening at the tip end, reduces shear forces
- sterile/pre-sterilized: gamma irradiated.



#### NOTE



*Autoclaving of GripTips is not recommended as they may warp during the process, which can lead to incorrect tip loading and obstruct precise well targeting.*



GripTips for benchtop pipetting systems: Purple 12.5 µl		Part No.
12.5 µl	5 XYZ racks of 384 tips, non-sterile	6453
	5 XYZ racks of 384 tips, sterile	6454
	5 XYZ racks of 384 tips, sterile, filter	6455
	5 XYZ racks of 384 tips, non-sterile, LONG	6403
	5 XYZ racks of 384 tips, sterile, LONG	6404
	5 XYZ racks of 384 tips, sterile, filter, LONG	6405
	5 XYZ racks of 384 tips, sterile, filter, SHORT	6475
12.5 µl low retention	5 XYZ racks of 384 tips, non-sterile	6553
	5 XYZ racks of 384 tips, sterile	6554
	5 XYZ racks of 384 tips, sterile, filter	6555
	5 XYZ racks of 384 tips, non-sterile, LONG	6503
	5 XYZ racks of 384 tips, sterile, LONG	6504
	5 XYZ racks of 384 tips, sterile, filter, LONG	6505
	5 XYZ racks of 384 tips, sterile, filter, SHORT	6575

GripTips for benchtop pipetting systems: Yellow 50 µl, 125 µl		Part No.
50 µl, 125 µl	5 XYZ racks of 384 tips, non-sterile	6463
	5 XYZ racks of 384 tips, sterile	6464
	5 XYZ racks of 384 tips, sterile, filter	6465
50 µl, 125 µl low retention	5 XYZ racks of 384 tips, non-sterile	6563
	5 XYZ racks of 384 tips, sterile	6564
	5 XYZ racks of 384 tips, sterile, filter	6565

<b>GripTips for benchtop pipetting systems: Green 300 µl</b>		<b>Part No.</b>
<b>300 µl</b>	5 inserts of 96 tips, non-sterile, GREEN CHOICE	6432
	5 racks of 96 tips, non-sterile	6433
	5 racks of 96 tips, sterile	6434
	5 racks of 96 tips, sterile, filter	6435
	5 inserts of 96 tips, non-sterile, LONG, GREEN CHOICE	6482
	5 racks of 96 tips, non-sterile, LONG	6483
	5 racks of 96 tips, sterile, LONG	6484
	5 racks of 96 tips, sterile, filter, LONG	6485
	5 racks of 96 tips, non-sterile, WIDE BORE	6633
	5 racks of 96 tips, sterile, WIDE BORE	6634
	5 racks of 96 tips, sterile, filter, WIDE BORE	6635
<b>300 µl</b> low retention	5 racks of 96 tips, non-sterile	6533
	5 racks of 96 tips, sterile	6534
	5 racks of 96 tips, sterile, filter	6535

<b>GripTips for benchtop pipetting systems: Blue 1250 µl</b>		<b>Part No.</b>
<b>1250 µl</b>	5 inserts of 96 tips, non-sterile, GREEN CHOICE	6442
	5 racks of 96 tips, non-sterile	6443
	5 racks of 96 tips, sterile	6444
	5 racks of 96 tips, sterile, filter	6445
	5 inserts of 96 tips, non-sterile, SHORT, GREEN CHOICE	6492
	5 racks of 96 tips, non-sterile, SHORT	6493
	5 racks of 96 tips, sterile, SHORT	6494
	5 racks of 96 tips, sterile, filter, SHORT	6495
	5 racks of 96 tips, non-sterile, WIDE BORE	6643
	5 racks of 96 tips, sterile, WIDE BORE	6644
	5 racks of 96 tips, sterile, filter, WIDE BORE	6645
<b>1250 µl</b> low retention	5 racks of 96 tips, non-sterile	6543
	5 racks of 96 tips, sterile	6544
	5 racks of 96 tips, sterile, filter	6545
	5 racks of 96 tips, non-sterile, SHORT	6593
	5 racks of 96 tips, sterile, SHORT	6594
	5 racks of 96 tips, sterile, filter, SHORT	6595

<b>Automation friendly Clear Advantage™ reagent reservoirs</b>		<b>Part No.</b>
150 ml 	8 reservoir bases, automation friendly (microplate format), non-sterile	6301
	25 lids, sterile, polypropylene	6302
Polystyrene	Trial pack (1 base, 1 reservoir and 1 lid), polystyrene, sterile	6303
	30 reservoirs, individually sealed, sterile, polystyrene, incl. 1 trial pack	6317
	100 reservoirs, 4 sleeves of 25 inserts, sterile, polystyrene, incl. 1 trial pack	6318
Polypropylene	Trial pack (1 base, 1 reservoir and 1 lid), polypropylene, sterile	6308
	30 reservoirs, individually sealed, sterile, polypropylene, incl. 1 trial pack	6337
	100 reservoirs, 4 sleeves of 25 inserts, sterile, polypropylene, incl. 1 trial pack	6338
300 ml 	8 reservoir bases, automation friendly (microplate format), non-sterile	6305
	25 lids, sterile, polypropylene	6306
Polystyrene	Trial pack (1 base, 1 reservoir and 1 lid), polystyrene, sterile	6307
	30 reservoirs, individually sealed, sterile, polystyrene, incl. 1 trial pack	6327
	100 reservoirs, 4 sleeves of 25 inserts, sterile, polystyrene, incl. 1 trial pack	6328
Polypropylene	Trial pack (1 base, 1 reservoir and 1 lid), polypropylene, sterile	6309
	30 reservoirs, individually sealed, sterile, polypropylene, incl. 1 trial pack	6347
	100 reservoirs, 4 sleeves of 25 inserts, sterile, polypropylene, incl. 1 trial pack	6348

<b>Standard footprint polypropylene reagent reservoirs</b>		<b>Part No.</b>
96 Well, 300 ml 	25 reservoirs per case, pyramid bottom, non-sterile	6351
	25 reservoirs per case, pyramid bottom, pre-sterilized	6352
12 Column 	25 reservoirs per case, pyramid bottom, non-sterile	6361
	25 reservoirs per case, pyramid bottom, pre-sterilized	6362
8 Row 	25 reservoirs per case, pyramid bottom, non-sterile	6371
	25 reservoirs per case, pyramid bottom, pre-sterilized	6372



## Imprint

© 2021 INTEGRA Biosciences AG

All rights to this documentation are reserved. In particular the rights of reproduction, processing, translation and the form of presentation lie with INTEGRA Biosciences AG. Neither the complete documentation nor parts thereof may be reproduced in any way, or stored and processed using electronic media or distributed in any other way without the written consent of INTEGRA Biosciences AG.

This operating instruction manual has part number 129950, the version is V00. It applies to software version as of (see Toolbox - Device information):

---

Control unit (FW)	1.00 or higher
Instrument base (HW)	1.00 or higher

---

until a newer revision is released.

### Manufacturer

**INTEGRA Biosciences AG**  
CH-7205 Zizers, Switzerland  
T +41 81 286 95 30  
F +41 81 286 95 33

**INTEGRA Biosciences Corp.**  
Hudson, NH 03051, USA  
T +1 603 578 5800  
F +1 603 577 5529

[info@integra-biosciences.com](mailto:info@integra-biosciences.com)  
[www.integra-biosciences.com](http://www.integra-biosciences.com)

### Customer service

Please contact your local INTEGRA Biosciences representative.  
To find out name and address of your local representative go to  
[www.integra-biosciences.com](http://www.integra-biosciences.com).

Further information and operating instructions in other languages are available on  
[www.integra-biosciences.com](http://www.integra-biosciences.com) or on request [info@integra-biosciences.com](mailto:info@integra-biosciences.com).